



## Medical and First Aid Policy

<b>Policy Title</b>	<b>Medical &amp; First Aid &amp; Supporting Children with Medical Needs Policy</b> <i>(including Asthma and head injuries)</i>
<b>Version No</b>	<b>Ten</b>
<b>Written / Adopted Date</b>	Written July 2016 Reviewed November 2018 Reviewed Jan 2019 Reviewed March 2020 (following LB medication awareness in schools training March 2020) Reviewed March 21 to include reportable diseases Feb 2022-added Natasha's Law and nut free school July 2022-following medication training & added ref: epi pen January 2023 – ref: NHS updated guidance 061 December 2023 – headbump Feb 2024 – medicine & allergy minor change October 2024 – change to administering Calpol/paracetamol March 2025 – annual review
<b>This policy complies with WBC guidance</b>	<b>Yes</b>
<b>Linked Policies</b>	<b>Safeguarding, H&amp;S</b>
<b>Date shared with Staff</b>	<b>March 2025</b>
<b>Date Ratified by Governors</b>	<b>April 2025</b>
<b>Review Date</b>	<b>March 2026</b>



**"Growing together at the heart of God's community"**



**Trust Prayer:**

*We thank you, God of Love, for the gift of children,  
bless the work of our Trust, that in all we do  
young people may grow in wisdom and stature,  
and so come to know you,  
to love you and to serve you,  
as Jesus did.*

*We make our prayer in his name who is God  
with you and the Holy Spirit, now and for ever.*

*Amen*

## Supporting Pupils with Medical Conditions

### **Definition**

For the purposes of this policy, a medical condition is defined as a disease, illness, injury, genetic or congenital defect or a biological or psychological condition that lies outside the range of normal, age-appropriate human variation, or any physical, mental or emotional condition affecting a person's health, for which a person is receiving medical treatment, for which medical treatment is usually prescribed.

Medication – also referred to as medicine - is defined as a pharmaceutical drug, loosely defined as any chemical substance, active ingredient- or product comprising such which is intended for use in the medical diagnosis, cure, treatment, or prevention of disease. Medication in the UK will be labelled as one of three types:

- General Sales List. Also known as Over the Counter (available to purchase from supermarkets or pharmacies without the need for a pharmacist to dispense), indicated by "**GSL**" on packaging.
- Pharmacy Medicines. Available from a dispensing pharmacy without the need for a prescription, indicated by "**P**" on packaging
- Prescription Medicines. Only available from a dispensing pharmacy on presentation of an authorised prescriber, indicated as "**POM**" on packaging.

### **Rationale**

The Children and Families Act 2014 includes a duty for schools to support children with medical conditions.

Where children have a disability, the requirements of the Equality Act 2010 will also apply. Where children have an identified special need, the SEN Code of Practice will also apply.

All children have a right to access the full curriculum, adapted to their medical needs and to receive the on-going support, medicines or care that they require at school to help them manage their condition and keep them well.

We recognise that medical conditions may impact social and emotional development as well as having educational implications.

Our school will build relationships with healthcare professionals and other agencies and in order to support effectively pupils with medical condition

Governing bodies **must** ensure that arrangements are in place in schools to support pupils at school with medical conditions.

Governing bodies should ensure that school leaders consult health and social care professionals, pupils, and parents to ensure that the needs of children with medical conditions are effectively supported.

This medical policy will also be followed for the administration on non-medical substances, including but not limited to, items such as hand cream, sun lotion, lip balm, soaps etc.

### **Roles and Responsibilities**

The Named Person responsible for children with medical conditions is Laura Carroll assisted by First Aiders.

These people are responsible for:

- Informing relevant staff of medical conditions
- Arranging training for identified staff
- Ensuring that staff are aware of the need to communicate necessary information about medical conditions to supply staff and where appropriate, taking the lead in communicating this information
- Assisting with risk assessments for school visits and other activities outside of the normal timetable
- Developing, monitoring, and reviewing Individual Healthcare Plans
- Working together with parents, pupils, healthcare professionals and other agencies

The Governing Body is responsible for:

- Determining the school's general policy and ensuring that arrangements are in place to support children with medical conditions.

The Head Teacher is responsible for:

- Overseeing the management and provision of support for children with medical conditions
- Ensuring that sufficient trained numbers of staff are available to implement the policy and deliver individual healthcare plans, including to cover absence and staff turnover
- Ensuring that school staff are appropriately insured and are aware that they are insured

Teachers and Support Staff are responsible for:

- The day-to-day management of the medical conditions of children they work with, in line with training received and as set out in the IHCP
- Working with the named person, ensure that risk assessments are carried out for school visits and other activities outside of the normal timetable
- Providing information about medical conditions to supply staff who will be covering their role where the need for supply staff is known in advance

Pupils are responsible for:

- Providing information about how their condition affects them. They should be fully involved in discussions about their medical support needs and contribute as much as possible [at an age-appropriate level](#) to the development of, and comply with, their individual healthcare plan

Parents are responsible for:

- Providing the school with sufficient and up-to-date information about their child's medical needs. They may in some cases be the first to notify the school that their child has a medical condition
- Parents are key partners and should be involved in the development and review of their child's individual healthcare plan and may be involved in its drafting. They should carry out any action they have agreed to as part of its implementation, eg provide medicines and equipment and ensure they or another nominated adult are contactable at all times

- Both staff and parent/carers sign off the agreed health care plan

NB. Any teacher or support staff member may be asked to provide support to a child with a medical condition, including administering medicines. However, no member of staff can be required to provide this support.

The school nurse is responsible for:

- Notifying the school when a child has been identified as having a medical condition which will require support in school. Wherever possible this should be done before the child starts at our school
- Providing support for staff on implementing a child's individual healthcare plan and providing advice and liaison including regarding training

### **Procedure When Notification is Received That a Pupil Has a Medical Condition**

- The named person will liaise with relevant individuals, including as appropriate parents, the individual pupil, health professionals and other agencies to decide on the support to be provided to the child
- Where appropriate, an Individual Health Care Plan (IHCP) will be drawn up
- The child's details will be added to the pupil awareness file - 1) main copy housed in school office 2) copy in class register 3) copy in Breakfast Club
- The child's details will be added along with the IHCP to the pupil awareness file that the office show visitors (i.e.: supply staff, clubs, and coaches) so that all staff/visitors have the relevant information to ensure the child is supported correctly.
- Fire PEEP to be drawn up to include child's individual needs.
- Appendix A outlines the process for developing individual healthcare plans

### **Individual Health Care Plans (IHCPs)**

- An IHCP will be written for pupils with a medical condition that is long term and complex.
- It will clarify what needs to be done, when and by whom and include information about the child's condition, special requirements, medicines required, what constitutes an emergency and action to take in the case of an emergency clarity
- Where a child has SEN but does not have a statement or EHC plan, their special educational needs will be mentioned in their IHP
- IHCPs will be reviewed annually, or earlier if evidence is provided that a child's needs have changed

### **Administering Medicines**

- If pupils need regular medication in order to manage a chronic or acute medical

condition, information will be collected either when a pupil starts school or returns to school following a diagnosis. Information may be shared during admission meetings, care planning meetings e.g., with a health care professional or via paperwork issued in the new starter packs.

- Children may also be required to take medication on a short-term basis, for example anti-biotics to control an infection or pain relief for a minor injury.
- Written consent must be provided by parents or guardians with parental responsibility for school staff to administer any medicines. Such consent is given through the Glazebury CE Primary School Medicine Form in Appendix B.
- All medicines - including medication that is also available "Over the Counter" must be prescribed WITH THE EXCEPTION OF CALPOL OR OTHER GENERIC PARACETAMOL FOR CHILDREN. It will not be possible to administer OTC medication unless it has been dispensed following a prescription for the named individual. For the purposes of this document, prescribed medication is defined as medication dispensed on the written instruction of a doctor, dentist, or nurse. It can also refer to medication supplied on the recommendation of a registered pharmacist whereby the pharmacy label advising of the following accompanies the medication and/or it's packaging.
  - Name of patient
  - Pharmacy details
  - Date dispensed
  - Dosage
  - Any relevant warnings
- Medicine must not be administered unless it has been prescribed for that child only.
- A copy of the Patient Information Leaflet must be retained (photocopies acceptable).

The parent must complete a school administering medicine form (see appendix C) completed. Medicines will only be accepted for administration if

- The prescription label is intact (Box and Bottle to be the same)
- It is in-date, i.e., the expiry date has not passed/ (It is the parent's responsibility to ensure the medicine if stored in school long term is in date).
- The container / bottle is labelled with child's name
- It is provided in the original container as dispensed by a pharmacist and include instructions for administration, dosage, and storage.
- The exception to this is insulin which must be in date but will generally be available inside an insulin pen or pump, rather than in its original container.

Parent must also use the administering medicine form to record the following information:

- Time medicine was first administered

- How many days the medicine has been taken for
- Time to be given and frequency
- Duration of course.
- Possible side effects of medication.
- Does this medicine contain paracetamol?
- How much medication is being provided – e.g., is the bottle full,  $\frac{3}{4}$  full,  $\frac{1}{2}$  full or  $\frac{1}{4}$  full. Staff will document how much medication is left when it is handed back to parent/carers.

Parents must give the first dose of any new course of antibiotics. If parents request their child is to be given paracetamol, details of dosages given in the past 24 hours must be provided.

If a medicine is prescribed for 3 x daily, children can take it before school, after school and bedtime. There is no need for it to be given in school. Although, note if the child attends after school club there may be a need as there will not be time in the evening for the parent to fit in two doses.

- When administering medicine or inhaler – TWO staff members must sign the reverse of the medicine request log. Detailing: Time / dose/ who administered. One member of staff to complete and administer and the other member of staff to check and counter sign.
- The administering member of staff to bring the child, medicine and form to the library area/office area. Relevant staff will be the second checker and countersign the form. This must be done at point of medicine administration
- This form must also be signed if child refuses the medicine and if this is the case the parent/carers must be contacted.
- If a dose is missed, then this must be recorded, and parent/carers must be notified.
- A double up dose must never be taken.
- Any changes to medication dose can only be accepted when given in writing from a prescriber or consultant.
- School will review these medicines on an annual basis (end of academic year) and send out of date medicine home and write to request replacement medicine for start of new term in September.

### **Disposal of needles and other sharps.**

- Step 1: Place all needles and other sharps in a sharp's disposal container (usually a yellow container) immediately after they have been used.
- Step 2: Dispose of used sharps disposal containers are arranged via our local

medical centre in Culcheth.

### **Guidelines for the treatment of Asthma**

A detailed section on management of asthma can be found in Appendix C. These comprehensive guidelines have been produced and issued by Warrington Borough Council in partnership with local NHS trusts.

### **Children with Epi-pen for severe allergies**

Epi-pens are kept in the classroom in a non-locked cupboard and are clearly labelled so that in the event of a severe allergic reaction that requires administering of the Epi-pen, it is easily accessible to staff. If the child is in a different area in school ie: hall, playground field, breakfast club or extended provision a member of staff takes the epi pen with them and keeps it with them in the event it is needed.

All staff are aware which children have an epi-pen and know the location of Epi-pen(s).

If the child attends an event outside school then a member of staff will take the epi pen with them along with the school first aid kit, inhaler etc.

### **Storage of medicines:**

1. Refrigerated medicines (including insulin) to be kept in the locked medicine fridge in the staff room (key is stored on hook and MUST BE OUT OF SIGHT)
2. Unrefrigerated medicines and needles/sharps to be kept in the locked medicine cupboard in the staff room. (Key is stored on hook and MUST BE OUT OF SIGHT)
3. Used Sharps to be kept in the sharps box which is kept in the staff room or the sharps box which is used for school trips in the school trip first aid box and then disposed of when required via our local medical Center in Culcheth.
4. KS2 children will have their inhalers on them at all times (either on the desk in front of them or in their pockets at playtime. (Name will be on them). This will encourage responsibility to manage their own condition.
5. KS1 children will have their inhalers stored in the medical box which the teacher has.
6. If children are attending our BC/ASC – this information should be passed to ASC staff from the class teacher/TA.
7. If a child uses an inhaler this must be taken to ASC with the child.
8. Oral or “internal” medicines are to be stored separately from external only medicines.
9. Epi-pens to be kept in the classroom for quick accessibility. The Epi-pen to be stored in an unlocked cupboard, out of reach of children, and clearly labelled.

Natasha's Law from October 2021.

Natasha's Law requires that any food that is prepacked for direct sale (PPDS)

must display the name of the food and a list of ingredients directly on the packaging or label. If the food contains any of the 14 prescribed allergens (see below), these must be highlighted or emboldened on the label.

If food is prepared on site, check the pupils awareness file for any specific dietary needs / allergies to ensure the child's needs are met.

- Celery
- Cereals containing gluten
- Crustaceans
- Eggs
- Fish
- Lupin
- Milk
- Molluscs
- Mustard
- Nuts
- Peanuts
- Sesame seeds
- Sulphur dioxide
- Soya

Please refer to our school allergy policy for further information regarding managing allergies.

### **Record keeping**

- Written records will be kept of all medicines administered to children. This will be done either on Appendix B or C (As above). These forms will be housed in the class pupil awareness file.
- At the end of the course of medicine the completed medicine forms are filed away in the archive storage (photocopier room). There is a paperwork storage packet that remains open on the top shelf for ease of filing the paperwork.
- It is the parent's responsibility to ensure the medicine is in date if stored in school.
- While we have the medicine on the premises, it will be stored either in the lockable fridge or lockable cabinet in the staff room. The form will be in the classroom housed in the pupil awareness file.
- Governing bodies should ensure that written records are kept of all medicines administered to children. Records offer protection to staff and children and provide evidence that agreed procedures have been followed. Parents should be informed if their child has been unwell at school.
- Children that have insulin administered for "Carb Counting" should have an individual record kept with their "Daily Insulin Dose Diary" which is their personal diary. Staff must annotate and initial the diary whenever a dose has been administered.

## **Action in Emergencies**

- Request an ambulance – dial 999 and be ready with the information below. Speak slowly and clearly and be ready to repeat information if asked.
  1. The school's telephone number: 01925 949404
  2. Your name:
  3. Your location: Glazebury C.E Warrington Road, Warrington WA3 5LZ
  4. Provide the exact location of the patient within the school
  5. Provide the name of the child and a brief description of their symptoms
  6. Inform ambulance control of the best entrance to use and state that the crew will be met and taken to the patient. (i.e., Hurst Lane and not gates on Warrington Road)
- Ask office staff to open relevant gates for entry and guide ambulance crew to patient.
- Member of school staff to stand on Warrington Road to guide ambulance to carpark.
- Contact the parents to inform them of the situation
- A member of staff should stay with the pupil until the parent/carer arrives. If a

Please note an emergency defibrillator is housed in the main corridor outside the hall.

Emergency Salbutamol Inhaler is kept alongside this.

Epi-pen is kept with the child at all times

parent/carer does not arrive before the pupil is transported to hospital, a member of staff should accompany the child in the ambulance.

## **Allergies**

Children who have allergies/intolerances or specific food requirements (ie: vegetarian or foods for religious reasons). This information is recorded on our internal MIS system (Iris), which automatically transfer the information to parentpay so that the kitchen can see on their IPAD what foods children are allergic to. The information is also recorded in our pupil awareness file, master copy is housed in the office, copy in each classroom and copy for Breakfast/After School club. A Pen portrait is also prepared by the class teacher, this is housed with the pupil awareness information. Parents are provided with a copy of their child's Pen portrait (medical) at the same time as any IEP. It is parents responsibility to inform school of any amendments.

Children with allergies/intolerances/specific food requirements are always served their food first within their year group and on cutlery which is edged in red / red knives and forks and a red cup.. This procedure is also adhered to by breakfast club, extended provision and any events eg: disco's that we run.

When new children start school, staff are also verbally updated so they are aware of new starters and their needs.

Crockery edged with red rather than blue and red cups and cutlery used for all children with specific food needs.

Children with Epi-pens have them close by at all times.

Also refer to school allergy policy.

### **Staff Training and Support**

- Staff Training matrix for first aid is monitored termly.
- Or when deemed necessary as roles and responsibilities change. Individual training needs are identified specifically at the time of a new responsibility.
- Relevant healthcare professionals will normally lead on identification, type and level of training.
- Staff supporting children with medical needs will be trained through a combination of school nurse, parent and NHS hospital staff. Bespoke training needs will be identified as appropriate to individual pupil needs.
- Whole school pupil awareness training is a part of the school's annual CPD safeguarding training which takes place at the start of the school year.
- Staff who start part way through the school year will receive this training as part of their induction in accordance with the schools induction policy.
- Supply staff training is supported by middle leader and admin staff induction.
- Training matrix is in place and is monitored for refresher training required.
- All staff are made aware when new pupils join who may have additional needs.

### **First Aid/Accident/Incident Recording Procedures**

- First aiders are identified on posters around school showing names and photographs so all aware.
- First Aid training matrix is in place and first aid training records are monitored by office staff to ensure refresher training is carried out.
- First aid books are kept – 1) by all first aiders and 2) spare in the office.
- The first aid books are in duplicate
  - The white copy goes home with pupil
  - The second copy (which is pink) – gets taken out of book at time by first aider and put in the wallet in the office. Accident slips must not be left in books or in classrooms.
- Half Termly – a member of the safeguarding joined up care team, collates half terms accidents and reports in meeting of their findings. This is to see if there are any trends that can be removed.
- These copies along with half terms analysis sheet are archived in paperwork storage room.
- Summary of half terms accidents are then shared in weekly briefing to make all staff aware of trends and / or problematic areas.

## **First Aid involving Head Injuries**

- If a pupil is involved in an accident/incident that results in an injury to the head (including forehead, eyes, nose, cheeks or chin) which is minor and there is no mark/lump to be seen a standard Spider text will be sent out to inform first contact.

Standard Message Reads: Please be aware your child has received a minor bump to the head. They have been seen by a first aider & assessed as well. Accident form issued.

- If a pupil is involved in an accident/incident that results in an injury to the head (including forehead, eyes, nose, cheeks or chin) which leaves a mark/lump the First aider / Admin will telephone and speak to the parents to advise to inform.
- The accident slip along with a head bump letter is given to the parents/carer at the end of school day. See appx D for copy of letter to be attached.
- The child has a head bump sticker applied to their jumper as a visual reminder to the staff to monitor and also will be an alert to the parent.
- If the accident is more serious then the Head Teacher/SBM to be informed immediately
- A HSA1 accident investigation / HSA2 Physical Verbal attach / HSA3 Work related reportable illness / HSA4 near miss form is completed.
- An investigation is carried out, the paperwork is given to SBM who if needed will:
  - Report to H&S Education Compliance. Dependent on severity of accident, this will either be done verbally or via email.
  - Record on spread sheet for reporting to Governors at next scheduled meeting.

If more serious accident/injury then the following reporting would apply:

- If a child goes directly to hospital and remains for 24 hours or is off sick from school for 7 days following an accident in school then this needs to be reported to Riddor.
- If there is a serious accident to an early years child (under 5 years of age) then this needs reporting to OFSTED. Refer to Ofsted 110009 published Feb 2011 – copy on G:Drive and in Accident report box file in office.

## **Activities Beyond the Usual Curriculum**

- Reasonable adjustments will be made to enable pupils with medical needs to participate fully and safely in day trips, residential visits, sporting activities and other activities beyond the usual curriculum
- When carrying out risk assessments, parents/carers, pupils and healthcare professionals will be consulted where appropriate.
- All clubs/coaches/teachers/staff are made aware of all pupils (& staffs) medical needs. This file is shown as part of induction/signing in safeguarding procedure.
- Where pupils are to participate in school trips and residential/out of school activities, information is collated and a Risk Assessment is put in place. This information is reviewed and entered onto Evolve (if applicable).
- The Breakfast Club, EYFS Extended Provision and After School Curriculum Clubs in operation at school is managed and run by school staff. The usual daytime school

procedures are replicated and followed in these extended services.

### **Infection Control and Notifiable Diseases**

Schools and nurseries are common sites for transmission of infections. Children are particularly susceptible because:

- they have immature immune systems
- have close contact with other children
- sometimes have no or incomplete vaccinations
- have a lower levels of understanding in relation to hygiene practices

Glazebury Primary school follows guidelines set out by Public Health England, who provide information for staff about managing a range of common and important childhood infections in settings including schools and nurseries, including advice on whether children need to be excluded (due to illness) and for how long. The guidelines can be found at the link below.

**<https://www.gov.uk/government/publications/health-protection-in-schools-and-other-childcare-facilities>**

Certain infections and diseases must be reported to local authority proper officers under the Health Protection (Notification) Regulations 2010: A list of notifiable diseases can be found at

**<https://www.gov.uk/guidance/notifiable-diseases-and-causative-organisms-how-to-report#list-of-notifiable-diseases>**

Refer to schools pandemic and infection control policy.

### **Unacceptable Practice**

The following items are not generally acceptable practice with regard to children with medical conditions, although the school will use discretion to respond to each individual case in the most appropriate manner.

- preventing children from easily accessing their inhalers / medication and administering their medication when and where necessary.
- assuming that every child with the same condition requires the same treatment
- ignore the views of the child or their parents; or ignore medical evidence or opinion, (although this may be challenged)
- sending children with medical conditions home frequently or prevent them from staying for normal
- school activities, including lunch, unless this is specified in their individual healthcare plans
- if the child becomes ill, sending them to the school office or staff room unaccompanied or with someone unsuitable
- penalising children for their attendance record if their absences are related to their medical condition e.g. hospital appointments
- preventing pupils from drinking, eating or taking toilet or other breaks whenever they

need to in order to manage their medical condition effectively

- Requiring parents, or otherwise making them feel obliged, to attend school to administer medication or provide medical support to their child, including with toileting issues. No parent should have to give up working because the school is failing to support their child's medical needs
- preventing children from participating, or create unnecessary barriers to children participating in any aspect of school life, including school trips, e.g. by requiring parents to accompany the child
- Secondary dispensing – i.e. asking someone else to give a medicine you have prepared.

### **Complaints**

- An individual wishing to make a complaint about actions regarding the school's actions in supporting a child with medical conditions should discuss this with the school in the first instance
- If the issue is not resolved, then a formal complaint may be made, following the complaints procedure as set out on the school website.

### **Outcomes**

Pupils at this school with medical conditions will be properly supported so that they have full access to the education we offer, including school trips and physical education. They will thrive and do well in our supportive and caring ethos. They will make friends and be fully integrated and valued members of our school community.

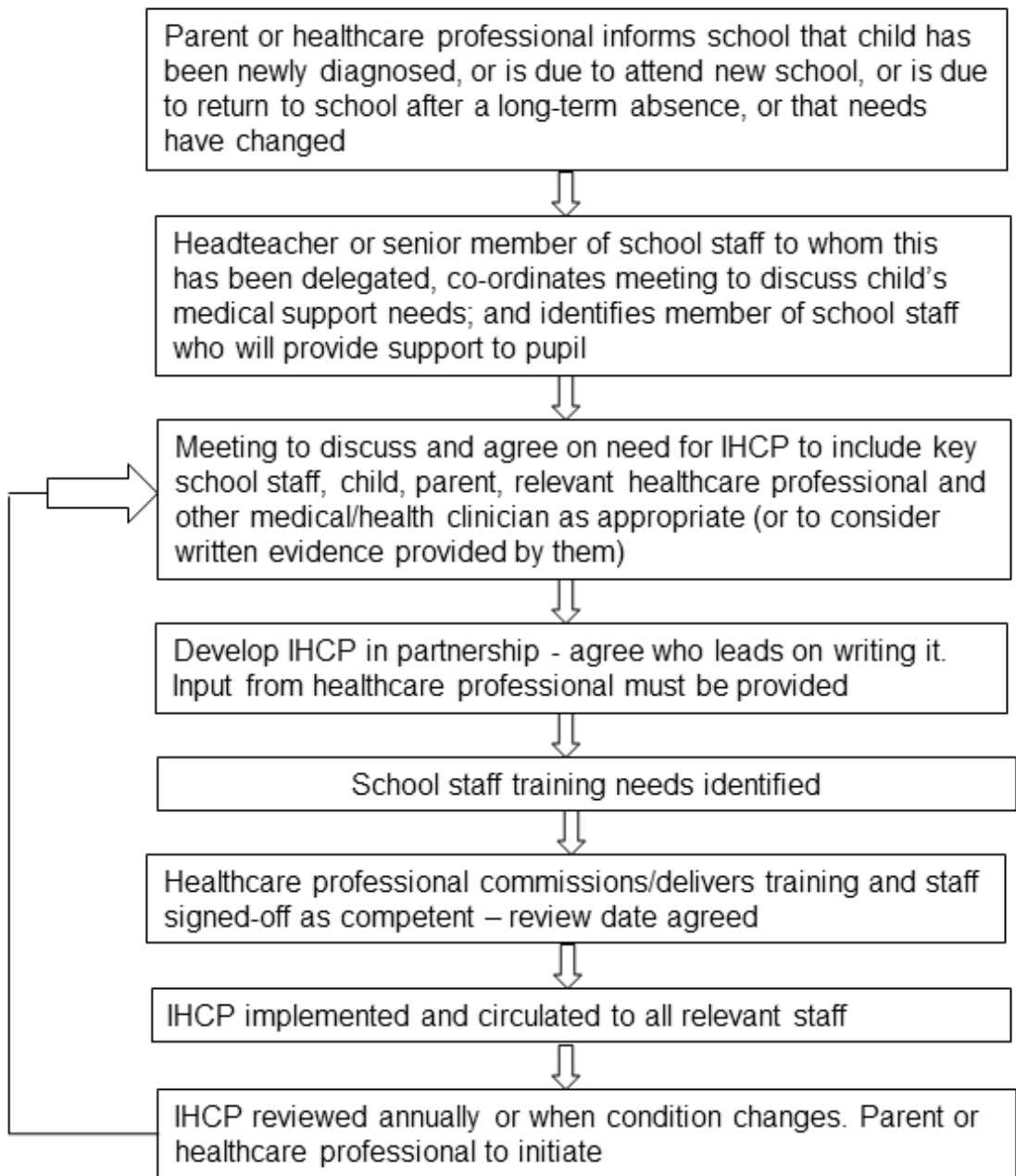

**Appendix A: individual healthcare plan**

Name of school/setting	
Child's name	
Group/class/form	
Date of birth	
Child's address	
Medical diagnosis or condition	
Date	
Review date	

**Family Contact Information**

Name	
Relationship to child	
Phone No: (landline)	
Phone No: (mobile)	
Name	
Relationship to child	
Phone no. (landline)	
Phone no: (mobile)	

**Clinic/Hospital Contact**

Name	
Phone no.	

**G.P.**

Name	
Phone no.	

Who is responsible for providing support in school

--

Describe medical needs and give details of child's symptoms, triggers, signs, treatments, facilities, equipment or devices, environmental issues etc

--

Name of medication, dose, method of administration, when to be taken, side effects, contra-indications, administered by/self-administered with/without supervision

--

Daily care requirements

--

Specific support for the pupil's educational, social and emotional needs

Arrangements for school visits/trips etc

Other information

Describe what constitutes an emergency, and the action to take if this occurs

Who is responsible in an emergency (*state if different for off-site activities*)

Plan developed with

Staff training needed/undertaken – who, what, when

Form copied to

Signed: ..... (Staff Member)

Signed: ..... (Parent Carer)

Date: .....

To be reviewed annually or prior to that if medical condition changes.

Dear Parent

#### DEVELOPING AN INDIVIDUAL HEALTHCARE PLAN FOR YOUR CHILD

Thank you for informing us of your child's medical condition.

I enclose a copy of the school's policy for supporting pupils at school with medical conditions for your information.

A central requirement of the policy is for an individual healthcare plan to be prepared, setting out what support the each pupil needs and how this will be provided. Individual healthcare plans are developed in partnership between the school, parents, pupils, and the relevant healthcare professional who can advise on your child's case.

The aim is to ensure that we know how to support your child effectively and to provide clarity about what needs to be done, when and by whom. Although individual healthcare plans are likely to be helpful in the majority of cases, it is possible that not all children will require one. We will need to make judgements about how your child's medical condition impacts on their ability to participate fully in school life, and the level of detail within plans will depend on the complexity of their condition and the degree of support needed.

A meeting to start the process of developing your child's individual health care plan has been scheduled for xx/xx/xx. I hope that this is convenient for you and would be grateful if you could confirm whether you are able to attend. The meeting will involve [the following people]. Please let us know if you would like us to invite another medical practitioner, healthcare professional or specialist and provide any other evidence you would like us to consider at the meeting as soon as possible.

If you are unable to attend, it would be helpful if you could complete the attached individual healthcare plan template and return it, together with any relevant evidence, for consideration at the meeting. I [or another member of staff involved in plan development or pupil support] would be happy for you contact me [them] by email or to speak by phone if this would be helpful.

Yours sincerely

## Appendix B

Information gathered in relation to the administering of medicines.

# ASTHMA

**Does your child have Asthma?**

**Does your child need to use an inhaler?**

**Are you helping your child to manage his/her Asthma effectively?**



*On average 2 children in every classroom in the UK have Asthma and every 16 minutes a child is admitted to hospital because of the condition. It is therefore essential that we are able to support your child with their Asthma and help them reach their full potential.*

- All children with diagnosed Asthma must have the correct medication in school – as well as at home, even if they do not use it on a regular basis.
- All inhalers and spacers, marked with your child's name and class, should be brought into school on the first day of each new school year and a medication form completed at the time of handing these into the school office.
- It is the responsibility of parents to ensure that medication is in date and to dispose of any out of date medication.

**Further information about Asthma can be found at [www.asthma.org.uk](http://www.asthma.org.uk)**

Childs Name: \_\_\_\_\_

Does NOT have asthma

Does have asthma and uses - \_\_\_\_\_

Signed \_\_\_\_\_ parent/carer Date: \_\_\_\_\_

**GLAZEBURY C.E. PRIMARY SCHOOL & Nursery - Asthma medical form**

Request for school, after school clubs and breakfast club to administer Medicine(s).

Dear Head Teacher,

I request that my child ..... be given the following inhaler(s) whilst in whilst in School/Breakfast club/EYFS Extended Provision/After School Curriculum Clubs

I confirm my child is aware how to correctly administer their own inhaler

Name of inhaler	Expiry date of inhaler	Date prescribed	Dose prescribed	Maximum daily dose	Time to be given

- I agree that the following complies with the school Medical & First Aid Policy:
- The above medication has been prescribed by the doctor, dentist, nurse or pharmacist
- It is clearly labelled indicating contents, dosage and child's name in full.
- I agree it is the parent's responsibility to ensure the inhaler is in date.
- I agree to inform School, ASC and Breakfast club of any change in dose immediately.

Name of parent/guardian: .....

Signed:..... Date: .....

Please note: Medication will not be accepted by the school unless this form is completed and signed by the parent or legal guardian of the child.

The Governors and Head Teacher reserve the right to withdraw this service.

---

The inhaler will be returned to you at the end of the academic year or during the year if expiry date is met.

Signature of parent to confirm receipt of inhaler

Date of inhaler returned to parent

.....

.....

## GLAZEBURY CE PRIMARY SCHOOL- Medicine Medical Form

Request for school, after school clubs and breakfast club to administer Medicine(s).

(This includes lip balms, cough sweets, sun cream)

Dear Head Teacher,

I request that my child ..... be given the following medicine(s) whilst in School/Breakfast club/EYFS Extended Provision/After School Curriculum Clubs

I confirm my child has had this medicine administered at home. The last occurrence was on

Date ..... at .....

Name of medicine	Expiry date of medicine	Check Dispensing Pharmacy name and contact on bottle	Dose prescribed	Date prescribed	Time to be given /Frequency	Any warnings?	Duration of course	Quantity of medication provided to school (eg half bottle, 12 tablets etc)

I agree that the following complies with the schools Medical & First Aid Policy:

- The above medication has been prescribed by the doctor, dentist, nurse or pharmacist (with the exception of Calpol or other generic children's paracetamol)
- It is clearly labelled indicating contents, dosage and child's name in full.
- Medication will only be given if it requires administering four times a day.
- I agree to inform school, ASC and Breakfast club of any change in dose immediately (accompanied by documentation from a relevant health care professional)
- Check the name & dosage on the bottle corresponds with the name on the box.
- It is the parents responsibility to ensure the medicine is in date and not past its bbe expiry date.

Does this medicine need to be stored in a Fridge?      YES/NO

Does this medicine contain paracetamol? YES / NO  
 Doses of paracetamol given in last 24 hours -----

How many days has your child been taking this medicine (to date)? .....

Name of parent/guardian: .....

Signed:..... Date: .....

Please note: Medication will not be accepted by the school unless this form is completed and signed by the parent or legal guardian of the child.



## Appendix C

### Asthma Guidelines



# Warrington Schools Asthma Guidelines

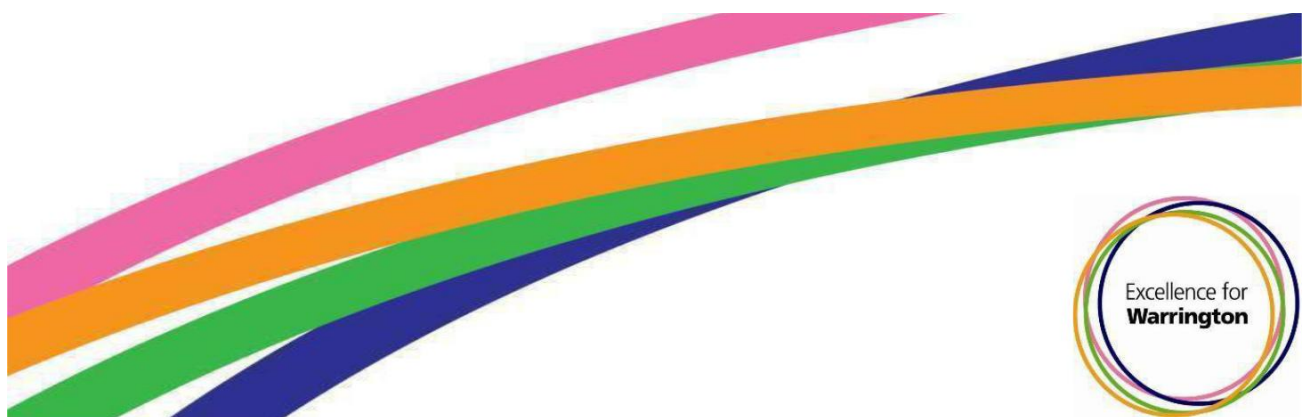

## Asthma Information

Asthma is a common, chronic, childhood disorder, affecting many school children.

With correct treatment and management the majority of children with asthma can lead a normal life, have less time off school and enjoy full participation in sport and other school activities.

### What is Asthma?

The airways in children with asthma are almost always inflamed and sensitive and are therefore quick to respond to anything that triggers (irritates) them. The muscles around the airways tighten and the lining becomes inflamed and narrow, making it difficult to breathe.

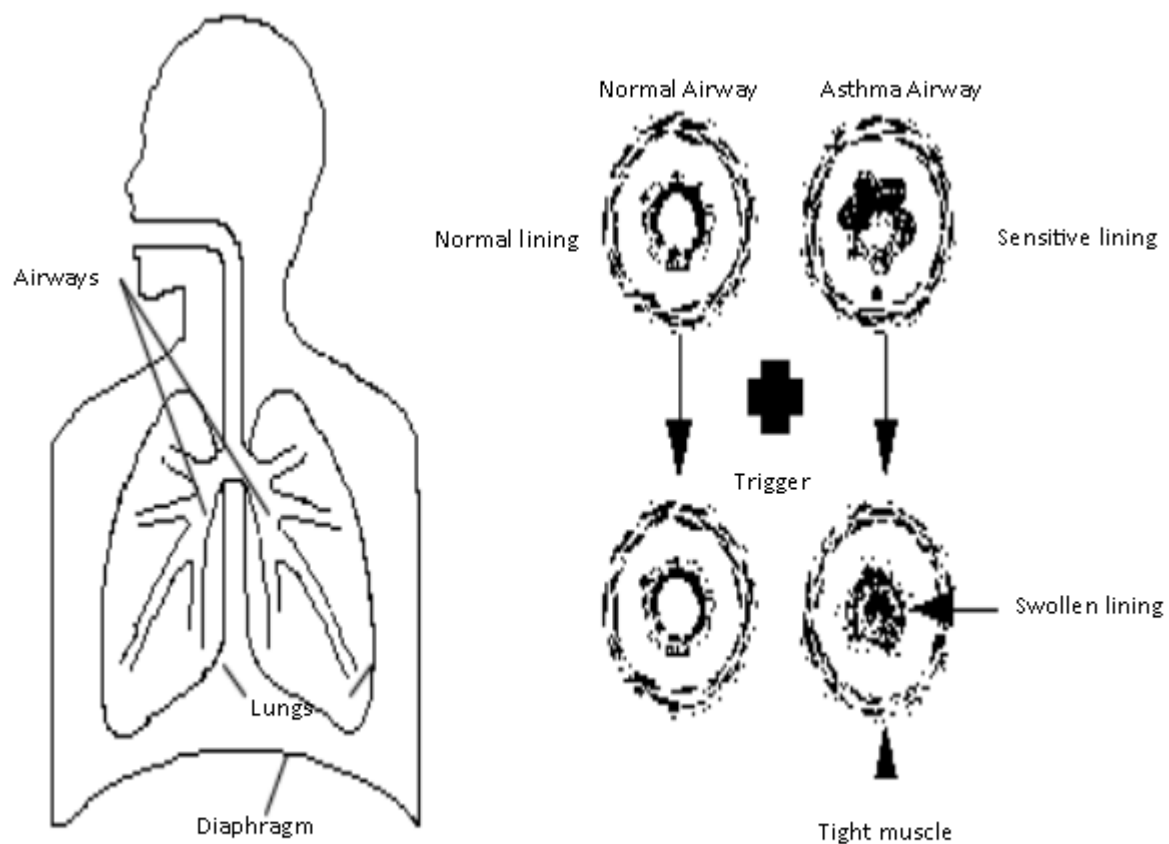

## **Cough**

Cough, especially after exercise, laughing, or breathing in cold air. The younger child may vomit, usually due to coughing.

Coughing most commonly occurs at night and with colds.

## **Wheeze**

Noisy breathing

## **Tight chest**

Older children may say that their chest feels tight. Younger children may describe the feeling as a tummy ache or a headache.

## **Breathlessness**

Breathlessness, especially after exercise

### **If asthma symptoms are getting worse, the child may:**

- Be unable to finish a sentence and find it harder to breathe out than in
- Be irritable, lethargic and unwilling to exercise
- Not achieve their full potential due to tiredness and absenteeism
- Be small for their age due to severe or poorly controlled asthma

Not every child with these symptoms has asthma but it is important to be aware that asthma could be the underlying cause of some children's problems.

## **Triggers**

A child with asthma may be affected by any one or more of these triggers:

- Colds and infection
- Dust and house dust mite
- Pollen, spores and moulds
- Feathers
- Furry animals
- Exercise, laughing

- Stress
- Cold air, change in the weather
- Chemicals, glue, paint, aerosols
- Fumes and cigarette smoke
- Pollution.
- Occasionally:
- Certain foods
- Some drugs e.g. Aspirin, Ibuprofen.



## Treatment

In the majority of cases asthma can be controlled with the appropriate medication and the correct use of inhalers and devices. There are two main types of inhalers.

### Relievers

These are usually blue. They quickly open the narrowed airways and therefore help the child to breathe more easily. They should be given for asthma symptoms of cough, wheeze or breathlessness. Some children take these 10 minutes before exercise or when they come into contact with known trigger factors.

**All children with asthma should have a reliever inhaler in school**

### Preventers

These are taken daily, usually morning and evening. They make the airways less sensitive to trigger factors by reducing the inflammation in the airways.

### **Other Medication**

Some children may require other medication by inhaler, nebuliser or by mouth.



## ASTHMA GUIDELINES

These guidelines have been produced locally, in partnership with Warrington Borough Council, Bridgewater Community Healthcare NHS Foundation Trust, Warrington Clinical Commissioning Group (CCG), Primary Care, Public Health, Education, Warrington and Halton Hospitals NHS Foundation Trust. They have been written to assist staff in providing a consistent approach to the care of children with asthma in school.

**These guidelines supersede all previous local asthma guidelines which should be destroyed.**

### A POSITIVE APPROACH

Pupils with asthma will be encouraged to fully participate in all school activities.

### ASTHMA EDUCATION

- The school has a responsibility to advise its staff (teachers, office staff and lunch time supervisors) on practical asthma management.
- Guidelines for the management of an acute asthma attack are included in this document. Schools should display in a prominent position.
- The School Nurses can play an important role and their involvement is encouraged. They can provide support for staff and liaison with parents/carers.
- Pupils who appear to be over-reliant on their reliever inhalers, are falling behind with their school work, or appear tired, may have poorly-controlled asthma. They may need to consult their doctor and, as such, their parents or carers should be informed by teachers.

### COMMUNICATION WITH PARENTS

1. It is recommended that a record of all pupils with asthma will be maintained and updated annually by the school.
2. It is the parent's/carer's responsibility to inform the school of details of treatment and any changes as they occur. This should be recorded on the asthma record.
3. Details of treatment should include specific guidance on the correct use of inhalers, (relievers, preventers) as well as any devices such as spacers.
4. Inhalers should be clearly labelled.

5. If a child has been given extra doses of their reliever in school, parents should be informed.
6. Parents should inform school if their child has increased symptoms or is on extra treatment such as steroids.
7. Children with severe asthma should have an asthma action plan, and be encouraged to display a photograph in school for identification purposes. If schools use this approach to identify pupils with medical conditions, confidentiality guidance needs to be maintained.

## **INHALERS**

- Reliever inhalers (often blue inhalers) are used to relieve asthma symptoms, especially in an acute attack. It is recommended that a spacer device should be used with a metered dose inhaler
- Preventer inhalers (often brown/orange/ purple/ red) are usually given at home, but occasionally a preventer inhaler may need to be taken in school.

**Preventer inhalers will not help in an acute asthma attack.**

## **ACCESS TO INHALERS**

- At school, the issue of access to inhalers is very important.
- Schools are advised to involve parents/carers in the decision of whether the inhaler(s) are held by the pupil or school.
- For younger children, the inhaler(s) will normally be kept by a named person, a spacer device is needed for use with their metered dose inhaler.
- Parents should be encouraged to provide an inhaler for school use.
- Inhalers should be stored away from extremes of heat.
- Parents to be aware of the expiry date of the inhalers.
- School need to inform parents when the child is unwell.

**IT IS ESSENTIAL THAT PUPILS WITH ASTHMA HAVE IMMEDIATE ACCESS TO THEIR RELIEVER INHALER AT ALL TIMES.**

**Delay in taking reliever treatment can lead to a severe attack and, in rare cases, could even prove fatal.**

## **EMERGENCY SALBUTAMOL INHALERS IN SCHOOL (DOH September 2014)**

Following guidance from the above document schools will be allowed to keep a salbutamol inhaler/s with spacer device, for use in an emergency if a child does not have their own inhaler available (for example if it has been lost, is empty or out of date). This will only be used for those children who have been diagnosed with Asthma or have been prescribed a salbutamol inhaler and parents have given written consent.

Keeping an inhaler for emergency use will have many benefits. It could prevent an unnecessary and traumatic trip to hospital for a child, and potentially save their life.

Parents are likely to have greater peace of mind about sending their child to school.

Having a protocol that sets out how and when the inhaler should be used will also protect staff by ensuring they know what to do in the event of a child having an asthma attack.

Schools will develop their own policy/protocol.

### **PHYSICAL EDUCATION**

- Normal activity should be the goal for all but the most severely affected pupil with asthma. However, some young people with asthma may cough, wheeze or become breathless with exercise.
- Teachers should be aware that a number of pupils with asthma take a dose of their reliever inhaler BEFORE exercise. This helps to prevent exercise induced asthma. If the pupil develops asthma symptoms of cough, wheeze, breathlessness or chest tightness they should use their reliever inhaler again. Pupils should not be required to participate in games or sports if they say they are unable to do so, due to their asthma symptoms.
- The pupil/teacher should ensure that the reliever inhaler is taken to the sports field.

### **PETS**

Pets in the classroom (hamsters, guinea-pigs etc.) may trigger asthma symptoms in some children with asthma. If kept at school, pets should be housed away from the classroom.

### **SCIENCE LABORATORIES**

Fumes from science experiments may trigger symptoms or attacks in pupils with asthma. Fume cupboards should be used to avoid this.

### **ART MATERIALS**

Aerosols and similar products may trigger symptoms for children with asthma. A well-ventilated area may minimise the risk.

## **PASSIVE SMOKING**

Although all schools have a no smoking policy, staff and pupils should be aware that inhaling someone else's cigarette smoke may trigger asthma symptoms

## **OUT OF SCHOOL ACTIVITIES**

It is the responsibility of the parent/carer to ensure that the school is fully informed of any medication that may be required. Provision should be made by parents for medication to accompany the child.

Details of trips should be made known to parents and activities assessed as to the suitability for the individual child, and adapted if necessary.

## **SUCCESS INDICATOR**

The positive approach to the management of asthma by school staff, parents and pupils will enable the majority of pupils with asthma to participate fully in the life of the school.

## **ACUTE ASTHMA ADVICE**

Refer to advice sheet in pack: **“What To Do in an Asthma Attack”**

## **REFERENCES & RESOURCES**

Asthma UK [www.asthma.org.uk](http://www.asthma.org.uk)

Department for Education and Skills and Department of Health (2005) Managing medicines in schools and early years settings [online]. Available at:

[https://webarchive.nationalarchives.gov.uk/20130124065832/http://www.dh.gov.uk/prod\\_c\\_onsum\\_dh/groups/dh\\_digitalassets/@dh/@en/documents/digitalasset/dh\\_4108490.pdf](https://webarchive.nationalarchives.gov.uk/20130124065832/http://www.dh.gov.uk/prod_c_onsum_dh/groups/dh_digitalassets/@dh/@en/documents/digitalasset/dh_4108490.pdf)

Department for Education (2015) Supporting pupils at school with medical conditions: statutory guidance for governing bodies of maintained schools and proprietors of academies in England [online]. Available at:

[https://assets.publishing.service.gov.uk/government/uploads/system/uploads/attachment\\_data/file/803956/supporting-pupils-at-school-with-medical-conditions.pdf](https://assets.publishing.service.gov.uk/government/uploads/system/uploads/attachment_data/file/803956/supporting-pupils-at-school-with-medical-conditions.pdf)

Department of Health (2015) Guidance on the use of emergency salbutamol inhalers in schools [online]. Available at:

[https://assets.publishing.service.gov.uk/government/uploads/system/uploads/attachment\\_data/file/416468/emergency\\_inhalers\\_in\\_schools.pdf](https://assets.publishing.service.gov.uk/government/uploads/system/uploads/attachment_data/file/416468/emergency_inhalers_in_schools.pdf)

Health Conditions in School Alliance [www.medicalconditionsatschool.org.uk](http://www.medicalconditionsatschool.org.uk)

Scottish Intercollegiate Guidelines Network (SIGN) and the British Thoracic Society (2019). British guideline on the management of asthma: a national clinical guideline (SIGN 158) [online]. Available at:

<https://www.brit-thoracic.org.uk/quality-improvement/guidelines/asthma/>

Reviewed	July 2010
Reviewed	October 2014
Last Reviewed	December 2019
Next Review	December 2021

## How to use the Aerochamber Plus with a face mask

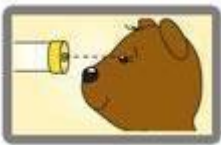

- Remove cap from the inhaler. Look inside the Aerochamber Plus to make sure there is nothing inside



- Shake the inhaler 4 to 5 times and place the mouthpiece of the inhaler into the back of the Aerochamber Plus

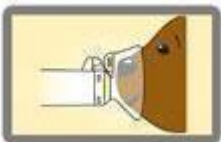

- Place the mask gently over the child's nose and mouth making sure a good seal is formed.



- Press the inhaler once only. Keep the mask in place on the child's face for 5 to 6 breathes of the child's normal breathing.



- Remove the mask. If a further dose is required wait 30 seconds and then repeat the above steps 2 – 5. After use remove inhaler from Aerochamber Plus and replace the cap.

## **IMPORTANT**

NEVER squirt the inhaler directly into your child's mouth as most of the drug will be wasted. ALWAYS give one dose into the Aerochamber plus at a time this will ensure that the correct dose is delivered.

### **To clean**

Remove the back of the aerochamber plus (do not remove mask). Soak both parts for 15 minutes in lukewarm water with mild liquid detergent.

Shake out excess water. **Do not rub dry.** Air-dry in an upright position. Replace the back of the Aerochamber plus once completely dry. Clean before first use then clean monthly as recommended by British Thoracic Society (BTS) guidelines 2011.



## How to use a Volumatic

1. Fit the two halves of the Volumatic together by lining up the notch on one half with the slot on the other.
2. Remove the cap from the inhaler.
3. Shake the inhaler 4 to 5 times and insert it into the back of the Volumatic.
4. Place the mouthpiece of the Volumatic into your mouth and seal your lips around it.
5. EITHER – Press the inhaler once and breathe in and out slowly and deeply for 5 breaths.

OR – Breathe out gently into the Volumatic, then press the inhaler once. Take a deep, slow breath in and hold the breath for 10 seconds. Then breathe out through the mouthpiece. Take a second deep breathe in but do not press the inhaler.

6. Remove the Volumatic from your mouth.
7. If another puff is required, wait 30 seconds and repeat steps 3 – 7.

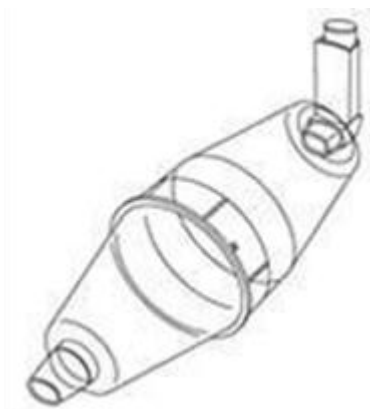

**IMPORTANT:** NEVER put the inhaler directly into your child's mouth as most of the drug will be wasted. Use only one puff in the Volumatic at a time this will ensure that the correct dose is delivered

**To clean:** Wipe the mouthpiece after each use. Once a month (as recommended by British Thoracic Society and SIGN guidelines 2011) take the Volumatic apart and wash in warm

soapy water, rinse, do not rub dry, allow  
it to dry naturally.

# What to do in an Asthma Attack

## Signs of an asthma attack are:

- Coughing
- Shortness of breath
- Wheezing
- Tightness in the chest
- Being unusually quiet
- Difficulty speaking in full sentences
- Tummy ache (sometimes in younger children)

## What to Do

- Keep Calm, Reassure the child
- Encourage the child to sit down in the position they find most comfortable
- Assist the child to immediately take 1 puff of their reliever inhaler (usually blue), preferably through a spacer. Please note that for each puff, the child should breathe in and out slowly for 5-6 breaths.
- Continue to assist the child to take 1 puff of their reliever inhaler every 30 to 60 seconds (up to 10 puffs) until symptoms improve.

**(Reliever medicine is very safe)**

**If there is No Immediate Improvement or signs of a Severe Attack:  
(see below: Red Box)**

## Call 999 Urgently if:

- There is no improvement
- The child is too breathless / exhausted to speak
- The child's lips are blue
- The child says they are having a 'bad' attack
- The child is frightened by the attack
- You are in any doubt about the child

**Continue to give the child 1 puff of their Reliever inhaler every 30-60 seconds until the ambulance/help arrives.**

## After a Minor Asthma Attack

- Minor attacks should not interrupt the involvement of a pupil with asthma in school activities.
- When the pupil feels better they can return to school activities.
- The parents/carers must always be told if their child has had an asthma attack.



# What to do in an Asthma Attack

## Important things to remember in an Asthma Attack

- **Never leave a pupil having an asthma attack**
- If the pupil does not have their reliever inhaler and/or spacer with them, send another teacher or pupil to get it from the designated room/area.
- In an emergency situation, if the child does not have their own inhaler in school, use the emergency salbutamol inhaler and spacer (according to school policy).
- **Reliever medicine is very safe.** During an asthma attack do not worry about a pupil overdosing.
- If an ambulance is called state that the child is having an asthma attack.
- Contact the pupil's parents or carers.
- A member of staff should always accompany a pupil taken to hospital by ambulance and stay with them until their parent or carer arrives.
- Generally staff should not take pupils to hospital in their own car, however, in some situations it may be the best course of action.
- Another adult should always accompany anyone driving a pupil having an asthma attack to emergency services.



Name.....

# Asthma/Wheeze Management Plan

## Asthma

Asthma is a condition that affects the small airways of the lungs, making them swollen and sensitive. These sensitive airways can react to certain 'triggers' such as viral infections ('catching a cold'), cigarette smoke, house dust mite, pets, pollen and exercise.

When your child comes into contact with one or more of these triggers, the muscles in the airways tighten up and the lining swells causing the airways to become narrow. Sticky mucus (phlegm) may also be produced.

## Symptoms of Asthma

- Cough
- Wheeze
- Shortness of breath
- Chest tightness

## Known Trigger Factors

**You/your child has been reviewed by ..... on**

...(Please

**destroy any previous management plans you have been given and retain this for reference)**

**Your Treatment is:**

Reliever (usually Blue).....

Preventer.....

(wash your child's face after each use, clean teeth and rinse mouth if possible)

Prednisolone.....

Other medication.....

Usual Peak Flow:

Predicted Peak Flow:

- If your child's condition gets worse or does not seem to be improving contact your GP, NHS 111 or A&E.
- Please take your medication and this leaflet with you.
- Please make your child's school aware of this plan.



## Asthma/Wheeze Management Plan

This plan may be used to help you to manage any future asthma/wheezy episodes. Step 1 should be followed everyday but if your child's symptoms are not improving or are getting worse go to the next stage of the plan and/or contact your GP.

Stage	Symptoms	Action
Green	<ul style="list-style-type: none"><li>• Well</li><li>• No cough, wheeze, breathlessness</li><li>• Doing normal activities</li></ul>	Continue using usual preventer medicine each day. Use reliever only when necessary
Yellow	<ul style="list-style-type: none"><li>• Unwell</li><li>• Getting a cold</li><li>• Coughing, wheezing, breathless day and/or night</li><li>• Reliever (blue) inhaler is working via spacer (with or without mask)</li></ul>	Give usual medication  And also 2-5 puffs Reliever inhaler 4-6 times a day for 5-7 days
Amber	<ul style="list-style-type: none"><li>• Coughing, wheezing, breathless getting worse, especially at night</li><li>• Reliever (blue) inhaler not lasting 4 hours or not working within 15 minutes</li></ul>	Give medication as step 2  And  See GP Urgently
Red	<ul style="list-style-type: none"><li>• Very unwell</li><li>• Reliever (blue) inhaler not helping at all</li><li>• Using tummy or neck muscles to breathe</li><li>• Breathing hard and fast</li></ul>	<b>Call 999</b> Or go to Accident and Emergency Dept

	<ul style="list-style-type: none"><li>• Too breathless to talk or eat</li><li>• Tired and lethargic</li><li>• Lips or fingers looking blue</li><li>• Peak Flow below 50% of usual</li></ul>	Give reliever inhaler (usually blue) 1 puff every 30-60 seconds up to 10 puffs  If symptoms remain severe, continue to use the reliever as stated until help arrives
--	---	--

## Contacts and further information

It is important to monitor your child's asthma regularly. This can be done by keeping a record of symptoms e.g. cough, wheeze, breathlessness and/or keeping a record of your child's peak flow readings (if you have been shown how to use one).

### Contact numbers

**For further advice about your child's asthma contact:**

- Your GP or Practice Nurse
- NHS 111
- Paediatric Acute Response Team (PART TEAM) 01925 843639
- Asthma UK: 08457 010203

### Useful websites and documents

📄 **Asthma UK** [www.asthma.org.uk/](http://www.asthma.org.uk/)

- **BTS & Sign 2019**

**Guidelines Last reviewed  
November 2019**

**Appendix D**  
**Head Injury Leaflet**

Advice for  
**Child Head Injury**

If you are unsure about any other symptoms  
or need further advice contact:-

- **NHS Direct on 0845 4647**
- Your Local GP
- Warrington GP Out of Hours **01925 650999**

**Useful Websites:-**

NHS Direct:

[www.nhsdirect.nhs.uk](http://www.nhsdirect.nhs.uk)

Child Accident Prevention Trust:

[www.capt.org.uk](http://www.capt.org.uk)

The Royal Society for the Prevention of Accidents ROSPA:

[www.rospea.co.uk](http://www.rospea.co.uk)



Produced by Warrington Public Health

This leaflet is designed to take  
the fear out of head injuries

It is quite natural to panic when your child suffers a head injury resulting in long fretful hours in A & E. However, the majority of head injuries are not serious. We hope this leaflet will explain the common symptoms, what you can do and when to seek medical help. After a head injury your child may feel tired, dizzy and/or sick, this is a very normal and common reaction.

### What you can do at home

- Keep calm and reassure your child
- After a head injury children often feel tired. It is alright for them to go to sleep as long as you keep an eye on them and check them regularly.
- They can eat and drink normally but they may also feel and be sick
- It is alright to give your child a children's painkiller, but do not give them more than is recommended on the packet.
- Let your child be as active as he or her wishes

Most patients recover uneventfully after a head injury but a few have complications, which may need prompt treatment. Certain symptoms may warn of a potentially more serious head injury, in some cases this may occur several days later.

If your child starts to suffer from any of the symptoms on the opposite page, please take them to the nearest Accident & Emergency Department as soon as possible.

### When do you need to go to hospital?

#### Children

- Severe headaches which do not respond to a children's painkiller
- Problems with eyesight (e.g. blurred vision)
- Repeated vomiting
- Appearing confused
- A fit or convulsion
- Problems understanding or speaking
- Problems walking or loss of balance
- Weakness in one or both arms or legs
- Clear fluid coming out of the ears or nose
- Bleeding from or deafness in one or both ears

To check if your child is responding:

Let your child go to sleep at the normal time and check every half hour before you go to bed. Shake them gently and make sure that they stir in response. There is no need to wake them unless you do not get a response.

#### Babies

- Inconsolable or high pitched crying
- Any fitting or twitching
- General irritability
- Increased drowsiness
- Repeated vomiting
- Change in colour – pale or waxy
- Floppiness

If your child has been admitted to Accident and Emergency you should avoid:-

- Leaving your child unattended for the first 48 hours after leaving hospital
- Giving your child sleeping tablets, sedatives or tranquilisers unless prescribed by their doctor

## **Appendix E of the Administration of Medicines Policy - Anaphylaxis**

### Anaphylaxis

Anaphylaxis is a severe and often sudden allergic reaction which may be life-threatening and must be treated immediately. Allergic reactions occur when a person's immune system responds inappropriately to a food or substance that it wrongly perceives as a threat.

### What causes an anaphylaxis reaction?

The common causes of allergies and anaphylaxis among children include:

- Peanuts
- Fish/seafood
- Milk
- Eggs
- Tree nuts (such as almonds, walnuts, cashew nuts, brazil nuts)
- Wheat
- Kiwifruit
- Less commonly, other foods

Non-food causes include wasp or bee stings, natural latex (rubber), penicillin or any other medicines.

Most healthcare professionals consider an allergic reaction to be anaphylaxis when it involves a

difficulty in breathing or affects the heart rhythm or blood pressure. Any one or more of the following symptoms may be present. These are often referred to as the ABC symptoms:

<b>A</b> irway	<b>B</b> reathing	<b>C</b> onsciousness/Circulation
Persistent cough Vocal changes (hoarse voice) Difficulty in swallowing Swollen tongue	Difficult or noisy breathing Wheezing (like an asthma attack)	Feeling lightheaded or faint. Clammy skin Confusion Unresponsive/unconscious (due to a drop-in blood pressure)

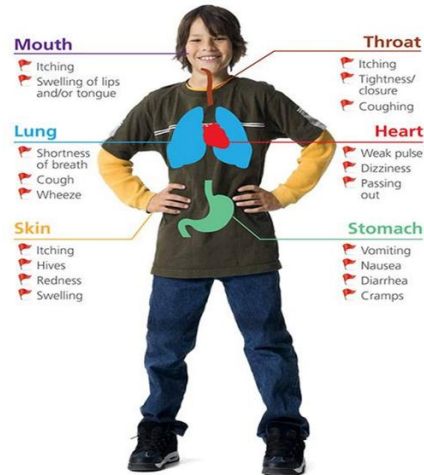

This school welcomes all pupils with allergies/anaphylaxis and aims to support these children in participating fully in school life, which could include ensuring that a child with a food allergy is able to eat a school lunch. We recognise the seriousness of this condition, but with accurate and comprehensive information we feel their condition can be managed.

We endeavour to do this by ensuring we have:

- ✓ all pupils have an up-to-date allergies and anaphylaxis healthcare plan
- ✓ an allergies and anaphylaxis register
- ✓ up-to-date allergies and anaphylaxis policy,
- ✓ an allergies and anaphylaxis lead,
- ✓ all pupils with immediate access to their adrenaline auto-injectors at all times,
- ✓ an emergency adrenaline auto-injector
- ✓ ensure all staff have regular anaphylaxis and adrenaline training
- ✓ promote anaphylaxis awareness pupils, parents/carers and staff.
- ✓ practical measures to eliminate or reduce the allergen in school.

### Anaphylaxis Healthcare Plan

To comply with our statutory duty to support pupils with medical conditions. The school will complete a Healthcare Plan with all pupils known to suffer from Anaphylaxis or who have been prescribed an Adrenaline Auto-injector.

The school Healthcare Plan ensures the school is effectively supporting a pupil's medical condition by providing clarity about the child's condition, what the child is allergic to, recognising the first signs of allergic reaction and what to do in an emergency.

Pupils parents/guardians, relevant staff, and if necessary, healthcare professionals will be consulted.

Our Healthcare Plan includes the following information:

- The child's details
- Contact details – Telephone and mobile numbers of parent or guardian and any other emergency contact details.
- Contact details of family GP
- The child's allergies – A list of the specific allergies and what to avoid
- A list of possible symptoms
- Prescribed Medication
- Details of Emergency Procedure – Including an assessment of symptoms, when and how to administer medication, contact numbers and the ambulance procedure
- Who can help? – A list of staff members who have been trained
- Consent and agreement – A parent or guardian must give written consent for staff to take responsibility for administering medication.

<https://www.gov.uk/government/publications/supporting-pupils-at-school-with-medical-conditions--3>

### Anaphylaxis Register

We have an anaphylaxis register of children within the school, which we update yearly. We do this by asking parents/carers if their child is diagnosed with anaphylaxis or has been prescribed an adrenaline auto-injector. When parents/carers have confirmed that their child is anaphylaxis or has been prescribed an adrenaline auto-injector we ensure that the pupil has been added to the anaphylaxis register and has:

- an up-to-date copy of their personal anaphylaxis healthcare plan,
- their adrenaline auto-injectors (Epi-Pen, Jext, Emerade) is with them in school,
- permission from the parents/carers to use the emergency Epi-Pen, Jext, Emerade adrenaline auto-injector if they require another dose before the emergency services arrive

### Anaphylaxis Lead

It is the responsibility of the anaphylaxis lead to manage the anaphylaxis register, update the anaphylaxis policy, manage the emergency Epi-Pen, Jext, Emerade adrenaline auto-injector (please refer to the Department of Health Guidance on the use of adrenaline auto-injectors in schools, September 2017) ensure measures are in place so that children have immediate access to their adrenaline auto-injector.

[https://assets.publishing.service.gov.uk/government/uploads/system/uploads/attachment\\_data/file/645476/Adrenaline\\_auto\\_injectors\\_in\\_schools.pdf](https://assets.publishing.service.gov.uk/government/uploads/system/uploads/attachment_data/file/645476/Adrenaline_auto_injectors_in_schools.pdf)

### Access to a child's Adrenaline Auto-injector

All children with anaphylaxis should always have immediate access to their adrenaline auto-injector. The adrenaline auto-injector medication acts on the whole body to block the progression of the allergic response. It constricts the blood vessels, leading to increased blood pressure, and decreased swelling.

Children are encouraged to carry their adrenaline auto-injectors as soon as they are responsible enough to do so. We would expect this to be by key stage 2. However, we will discuss this with

each child's parent/carer and teacher. We recognise that all children may still need supervision in administering their adrenaline auto-injector.

School staff are not required to administer adrenaline auto-injector to pupils however the school understands that in an emergency a failure to administer the child's medication could end in hospitalisation or even death.

Therefore, the school will ensure an adequate number of staff have had adrenaline auto-injector training and/or administering medication training and are happy to support children. Please refer to the Administering Medicines policy for further details about administering medicines.

### Emergency Adrenaline Auto-injector in school

Legislation which came into effect in 2017 enables schools in the UK to buy Adrenaline Auto-injector (AAls) without a prescription for emergency use on children who are at risk of anaphylaxis.

Adrenaline Auto-injector are intended for use in emergency situations when an allergic individual is having a reaction consistent with anaphylaxis, as a measure that is taken until an ambulance arrives.

Therefore, unless directed otherwise by a healthcare professional, the spare Adrenaline Auto-injector should only be used on pupils known to be at risk of anaphylaxis, where both medical authorisation and written parental consent for use of the spare Adrenaline Auto-injector has been provided.

Each kit contains:

- A pre-loaded Adrenaline Auto-injector.
- Instructions on using the device(s).
- Instruction on cleaning and storing the Adrenaline Auto-injector
- Manufacturer's information.
- A checklist of Adrenaline Auto-injector, identified by their batch number and expiry date, with monthly checks recorded.
- A note of the arrangements for replacing the Adrenaline Auto-injector.
- A list of children to whom the Adrenaline Auto-injector can be administered:
- A record of administration

Adrenaline Auto-injectors are available in different doses, depending on the manufacturer. The Resuscitation Council (UK) recommends that healthcare professionals treat anaphylaxis using the age-based criteria, as follows:

- For children age under 6 years: a dose of 150 microgram (0.15 milligram) of adrenaline is used (e.g. using an Epipen Junior (0.15mg), Emerade 150 or Jext 150 microgram device).
- For children age 6-12 years: a dose of 300 microgram (0.3 milligram) of adrenaline is used (e.g. using an Epipen (0.3mg), Emerade 300 or Jext 300 microgram device)

Once an Adrenaline Auto-injector has been used it cannot be reused and must be disposed of according to manufacturer's guidelines. Used Adrenaline Auto-injector can be given to the ambulance paramedics on arrival or can be disposed of in a pre-ordered sharps bin for collection by the local council.

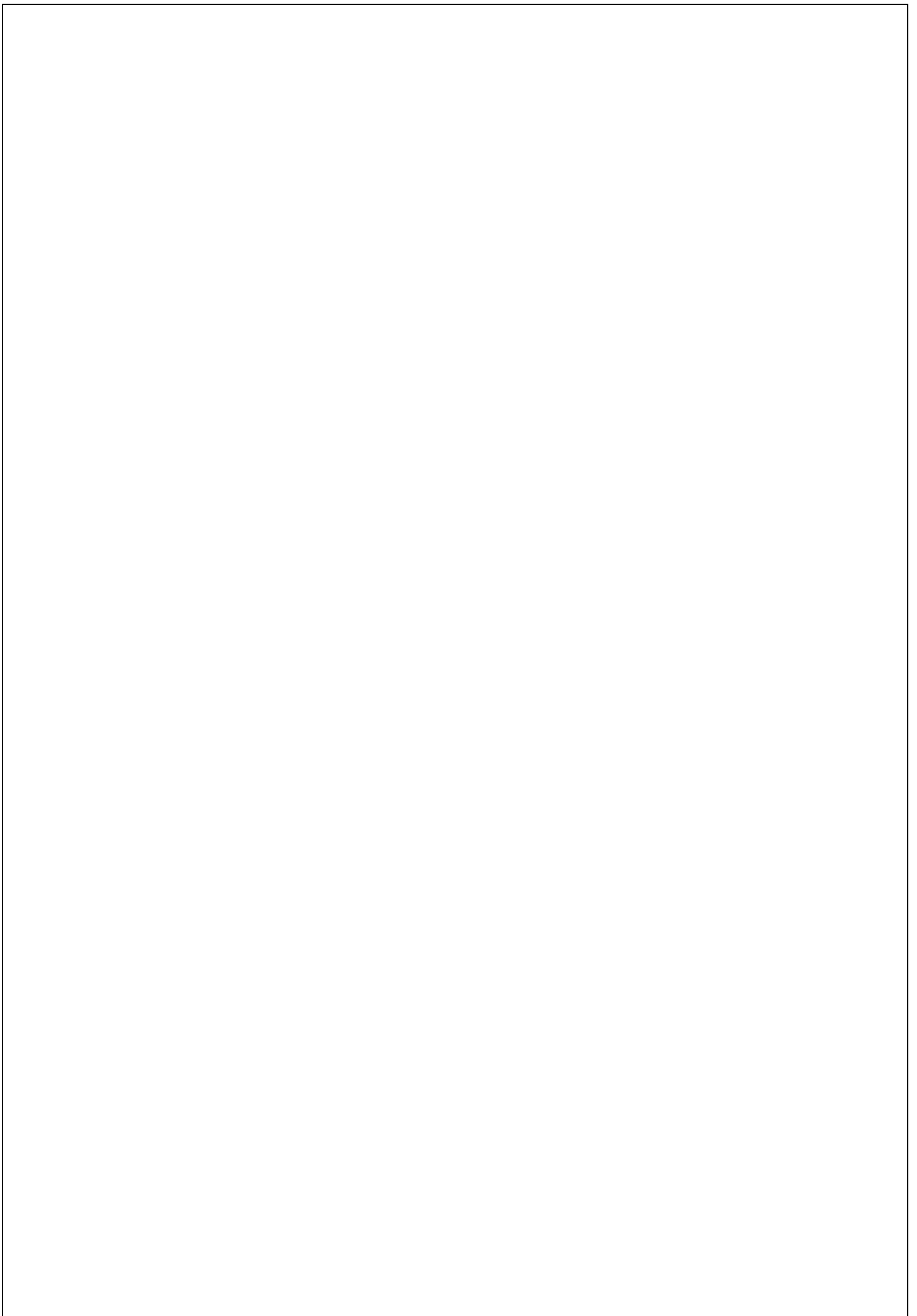

### Mild-moderate allergic reaction:

- Swollen lips, face or eyes
- Itchy/tingling mouth
- Hives or itchy skin rash
- Abdominal pain or vomiting
- Sudden change in behaviour

### ACTION:

- Stay with the child, call for help if necessary
- Locate adrenaline autoinjector(s)
- Give antihistamine according to the child's allergy treatment plan
- Phone parent/emergency contact



## Watch for signs of **ANAPHYLAXIS** (life-threatening allergic reaction):

### **A**IRWAY:

Persistent cough  
Hoarse voice  
Difficulty swallowing, swollen tongue

### **B**REATHING:

Difficult or noisy breathing  
Wheeze or persistent cough

### **C**ONSCIOUSNESS:

Persistent dizziness  
Becoming pale or floppy  
Suddenly sleepy, collapse, unconscious

### **IF ANY ONE (or more) of these signs are present:**

1. Lie child flat with legs raised:  
(if breathing is difficult,  
allow child to sit)



2. **Use Adrenaline autoinjector\* without delay**

3. **Dial 999** to request ambulance and say **ANAPHYLAXIS**

**\*\*\* IF IN DOUBT, GIVE ADRENALINE \*\*\***

### **After giving Adrenaline:**

1. Stay with child until ambulance arrives, do **NOT** stand child up
2. Commence CPR if there are no signs of life
3. Phone parent/emergency contact
4. If no improvement **after 5 minutes**, **give a further dose** of adrenaline using another autoinjector device, if available.

Anaphylaxis may occur without initial mild signs: **ALWAYS** use adrenaline autoinjector **FIRST** in someone with known food allergy who has **SUDDEN BREATHING DIFFICULTY** (persistent cough, hoarse voice, wheeze) – even if no skin symptoms are present.



## Food prepared on site – Breakfast club / extended Provision

Food prepared for the breakfast club is provided by the school and consist of low-risk foods e.g. toast, muffins, crumpets and a selection of drinks.

## Food prepared off site (Packed Lunches, Birthday celebrations and festive treats)

All parents providing a packed lunch for their child is made aware of any known allergens and are asked to co-operate with the school.

A “no sharing” policy is in place, for when children bring food from home, and every effort is taken to ensure that allergic children do not take or accept food from another child's packed lunch.

A “treat box” of known allergen-free treats is provided by the child's parents, to ensure that they are included in all special occasions.

Children with known allergens are encouraged to check with an adult before eating or before taking part in certain activities. Just a “is that okay for me?” will make the adult think again, and also teach the child awareness of their allergy and develop good management techniques.

## References

- Department of Health Guidance on the use of adrenaline auto-injectors in school  
[https://assets.publishing.service.gov.uk/government/uploads/system/uploads/attachment\\_data/file/645476/Adrenaline\\_auto\\_injectors\\_in\\_schools.pdf](https://assets.publishing.service.gov.uk/government/uploads/system/uploads/attachment_data/file/645476/Adrenaline_auto_injectors_in_schools.pdf)
- Department of Education Allergy Guidance for schools 17<sup>th</sup> November 2020  
<https://www.gov.uk/government/publications/school-food-standards-resources-for-schools/allergy-guidance-for-schools>
- Department of Education Supporting Pupils with Medical Conditions at School  
[https://assets.publishing.service.gov.uk/government/uploads/system/uploads/attachment\\_data/file/803956/supporting-pupils-at-school-with-medical-conditions.pdf](https://assets.publishing.service.gov.uk/government/uploads/system/uploads/attachment_data/file/803956/supporting-pupils-at-school-with-medical-conditions.pdf)
- Department of Education School food in England  
[https://assets.publishing.service.gov.uk/government/uploads/system/uploads/attachment\\_data/file/788884/School-food-in-England-April2019-FINAL.pdf](https://assets.publishing.service.gov.uk/government/uploads/system/uploads/attachment_data/file/788884/School-food-in-England-April2019-FINAL.pdf)
- Department of Education School Food Standards  
<https://www.gov.uk/government/publications/school-food-standards-resources-for-schools>
- Anaphylaxis Campaign  
<https://www.anaphylaxis.org.uk/information-training/our-factsheets/>
- Early Years Foundation Stage Statutory Guidance effective 1<sup>st</sup> September 2021  
[https://assets.publishing.service.gov.uk/government/uploads/system/uploads/attachment\\_data/file/974907/EYFS\\_framework\\_-\\_March\\_2021.pdf](https://assets.publishing.service.gov.uk/government/uploads/system/uploads/attachment_data/file/974907/EYFS_framework_-_March_2021.pdf)

Extraction from the EYFS Statutory Guidance effective from 1<sup>st</sup> September 2021

## Annex A: Criteria for effective Paediatric First Aid (PFA) training

- Training is designed for workers caring for young children in the absence of their parents and is appropriate to the age of the children being cared for.
  - Following training an assessment of competence leads to the award of a certificate.
  - The certificate must be renewed every three years.
  - Adequate resuscitation and other equipment including baby and junior models must be provided, so that all trainees are able to practice and demonstrate techniques.
  - The emergency PFA course should be undertaken face-to-face<sup>71</sup> and last for a
  - minimum of 6 hours (excluding breaks) and cover the following areas:
- ✓ Be able to assess an emergency situation and prioritise what action to take

- ✓ Help a baby or child who is unresponsive and breathing normally
- ✓ Help a baby or child who is unresponsive and not breathing normally
- ✓ Help a baby or child who is having a seizure
- ✓ Help a baby or child who is choking
- ✓ Help a baby or child who is bleeding
- ✓ Help a baby or child who is suffering from shock caused by severe blood loss
- ✓ (hypovolemic shock)

• 6. The full PFA course should last for a minimum of 12 hours (excluding breaks) and cover the elements listed below in addition to the areas set out in paragraph 5 (the emergency PFA training elements outlined in paragraph 5 should be delivered face to face).

- ✓ Help a baby or child who is suffering from anaphylactic shock
- ✓ Help a baby or child who has had an electric shock
- ✓ Help a baby or child who has burns or scalds
- ✓ Help a baby or child who has a suspected fracture
- ✓ Help a baby or child with head, neck or back injuries
- ✓ Help a baby or child who is suspected of being poisoned
- ✓ Help a baby or child with a foreign body in eyes, ears or nose
- ✓ Help a baby or child with an eye injury
- ✓ Help a baby or child with a bite or sting
- ✓ Help a baby or child who is suffering from the effects of extreme heat or cold
- ✓ Help a baby or child having: a diabetic emergency; an asthma attack; an allergic reaction; meningitis; and/or febrile convulsions

This child has the following allergies:

Name:

DOB:

Photo

### Mild/moderate reaction:

- Swollen lips, face or eyes
- Itchy/tingling mouth
- Hives or itchy skin rash
- Abdominal pain or vomiting
- Sudden change in behaviour

#### Action to take:

- Stay with the child, call for help if necessary
- Locate adrenaline autoinjector(s)
- Give antihistamine:  
..... (If vomited, can repeat dose)
- Phone parent/emergency contact

## ● Watch for signs of ANAPHYLAXIS (life-threatening allergic reaction)

Anaphylaxis may occur without skin symptoms. ALWAYS consider anaphylaxis in someone with known food allergy who has **SUDDEN BREATHING DIFFICULTY**

- |   |  |   |
|---|--|---|
| <b>A AIRWAY</b>   | <b>B BREATHING</b>   | <b>C CONSCIOUSNESS</b>  |
| <ul style="list-style-type: none"> <li>• Persistent cough</li> <li>• Hoarse voice</li> <li>• Difficulty swallowing</li> <li>• Swollen tongue</li> </ul> | <ul style="list-style-type: none"> <li>• Difficult or noisy breathing</li> <li>• Wheeze or persistent cough</li> </ul> | <ul style="list-style-type: none"> <li>• Persistent dizziness</li> <li>• Pale or floppy</li> <li>• Suddenly sleepy</li> <li>• Collapse/unconscious</li> </ul> |

**IF ANY ONE (OR MORE) OF THESE SIGNS ABOVE ARE PRESENT:**

- 1 Lie child flat with legs raised** (if breathing is difficult, allow child to sit)  



- 2 Use Adrenaline autoinjector without delay** (eg. EpiPen®) (Dose: ..... mg)
- 3 Dial 999** for ambulance and say ANAPHYLAXIS ("ANA-FIL-AX-IS")  
**\*\*\* IF IN DOUBT, GIVE ADRENALINE \*\*\***

#### AFTER GIVING ADRENALINE:

1. Stay with child until ambulance arrives, **do NOT stand child up**
2. Commence CPR if there are no signs of life
3. Phone parent/emergency contact
4. If no improvement **after 5 minutes**, give a further adrenaline dose using a second autoinjectable device, if available.

You can dial 999 from any phone, even if there is no credit left on a mobile. Medical observation in hospital is recommended after anaphylaxis.

### Emergency contact details:

1) Name: .....



2) Name: .....



**Parental consent:** I hereby authorize school staff to administer the medicines listed on this plan, including a 'spare' back-up adrenaline autoinjector (AAI) if available, in accordance with Department of Health Guidance on the use of AAI in schools

Signed: .....

Print name: .....

Date: .....

For more information about managing anaphylaxis in schools and "spare" back-up adrenaline autoinjectors, visit [sparepensinschools.uk](http://sparepensinschools.uk)

### How to give EpiPen®



**1** PULL OFF BLUE SAFETY CAP and grasp EpiPen. Remember: "blue to sky, orange to the thigh"



**2** Hold leg still and PLACE ORANGE END against mid-outer thigh "with or without clothing"



**3** PUSH DOWN HARD until a click is heard or felt and hold in place for **3 seconds**. Remove EpiPen.

### Additional instructions:

If wheezy, GIVE ADRENALINE FIRST, then asthma reliever (blue puffer) via spacer

This is a medical document that can only be completed by the child's healthcare professional. It must not be altered without their permission. This document provides medical authorization for schools to administer a 'spare' back-up adrenaline autoinjector if needed, as permitted by the Human Medicines (Amendment) Regulations 2017. During travel, adrenaline auto-injector devices must be carried in hand-luggage or on the person, and NOT in the luggage hold. This action plan and authorization to travel with emergency medications has been prepared by:

Sign & print name: .....

Hospital/Clinic: .....



Date: .....

This child has the following allergies:

Name: \_\_\_\_\_

DOB: \_\_\_\_\_

Photo

### Mild/moderate reaction:

- Swollen lips, face or eyes
- Itchy/tingling mouth
- Hives or itchy skin rash
- Abdominal pain or vomiting
- Sudden change in behaviour

### Action to take:

- Stay with the child, call for help if necessary
- Locate adrenaline autoinjector(s)
- Give antihistamine:  
\_\_\_\_\_ (if vomited, can repeat dose)
- Phone parent/emergency contact

## ● Watch for signs of ANAPHYLAXIS

(life-threatening allergic reaction)

Anaphylaxis may occur without skin symptoms: ALWAYS consider anaphylaxis in someone with known food allergy who has **SUDDEN BREATHING DIFFICULTY**

- |   |  |   |
|---|--|---|
| <b>A AIRWAY</b>   | <b>B BREATHING</b>   | <b>C CONSCIOUSNESS</b>  |
| <ul style="list-style-type: none"> <li>• Persistent cough</li> <li>• Hoarse voice</li> <li>• Difficulty swallowing</li> <li>• Swollen tongue</li> </ul> | <ul style="list-style-type: none"> <li>• Difficult or noisy breathing</li> <li>• Wheeze or persistent cough</li> </ul> | <ul style="list-style-type: none"> <li>• Persistent dizziness</li> <li>• Pale or floppy</li> <li>• Suddenly sleepy</li> <li>• Collapse/unconscious</li> </ul> |

**IF ANY ONE (OR MORE) OF THESE SIGNS ABOVE ARE PRESENT:**

- 1 Lie child flat with legs raised** (if breathing is difficult, allow child to sit)  

- 2 Use Adrenaline autoinjector without delay** (eg. Jext®) (Dose: \_\_\_\_\_ mg)
- 3 Dial 999** for ambulance and say ANAPHYLAXIS ("ANA-FIL-AX-IS")  
**\*\*\* IF IN DOUBT, GIVE ADRENALINE \*\*\***

### AFTER GIVING ADRENALINE:

- 1 Stay with child until ambulance arrives, **do NOT stand child up**
- 2 Commence CPR if there are no signs of life
- 3 Phone parent/emergency contact
- 4 If no improvement **after 5 minutes**, give a further adrenaline dose using a second autoinjectable device, if available.

You can dial 999 from any phone, even if there is no credit left on a mobile. Medical observation in hospital is recommended after anaphylaxis.

### Emergency contact details:

1) Name: \_\_\_\_\_  
 \_\_\_\_\_

2) Name: \_\_\_\_\_  
 \_\_\_\_\_

**Parental consent:** I hereby authorize school staff to administer the medicines listed on this plan, including a 'spare' back-up adrenaline autoinjector (AAI) if available, in accordance with Department of Health Guidance on the use of AAIs in schools

Signed: \_\_\_\_\_

Print name: \_\_\_\_\_

Date: \_\_\_\_\_

For more information about managing anaphylaxis in schools and "spare" back-up adrenaline autoinjectors, visit [sparepensinschools.uk](http://sparepensinschools.uk)

### How to give Jext®



**1**  
Form fist around Jext® and PULL OFF YELLOW SAFETY CAP



**2**  
PLACE BLACK END against outer thigh (with or without clothing)



**3**  
PUSH DOWN HARD until a click is heard or felt and hold in place for 10 seconds



**4**  
REMOVE Jext®. Massage injection site for 10 seconds

### Additional instructions:

If wheezy, GIVE ADRENALINE FIRST, then asthma reliever (blue puffer) via spacer

This is a medical document that can only be completed by the child's healthcare professional. It must not be altered without their permission. This document provides medical authorization for schools to administer a 'spare' back-up adrenaline autoinjector if needed, as permitted by the Human Medicines (Amendment) Regulations 2007. During travel, adrenaline auto-injector devices must be carried in hand luggage or on the person, and NOT in the luggage hold. This action plan and authorization to travel with emergency medications has been prepared by:

Sign & print name: \_\_\_\_\_

Hospital/Clinic: \_\_\_\_\_



Date: \_\_\_\_\_